

FM146 LIGHT DUTY ROLLER GUIDE FOR STEEL PIPE		
PART NO.	PIPESIZE	A
FM146-021	15nb	89
FM146-027	20nb	92
FM146-034	25nb	95
FM146-043	32nb	100
FM146-048	40nb	102
FM146-060	50nb	108
FM146-073	65nb	116
FM146-089	80nb	122
FM146-115	100nb	137
FM146-140	125nb	150
FM146-168	150nb	164

FINISH: GALVANISED

FM146 LIGHT DUTY ROLLER GUIDE FOR COPPER PIPE		
PART NO.	PIPESIZE	A
FM146-015	15cu	84
FM146-020	20cu	88
FM146-025	25cu	91
FM146-032	32cu	94
FM146-038	40cu	97
FM146-051	50cu	104
FM146-064	65cu	110
FM146-076	80cu	116
FM146-102	100cu	129
FM146-127	125cu	144
FM146-152	150cu	156

**FINISH: POLYESTER
POWDER COATED**

**'A' DIMENSION IS A MINIMUM, CAN BE INCREASED
TO SUIT INDIVIDUAL ON-SITE REQUIREMENTS**



LIGHT DUTY ROLLER GUIDE AND TIMBER FERRULE FOR STEEL PIPE

FM147

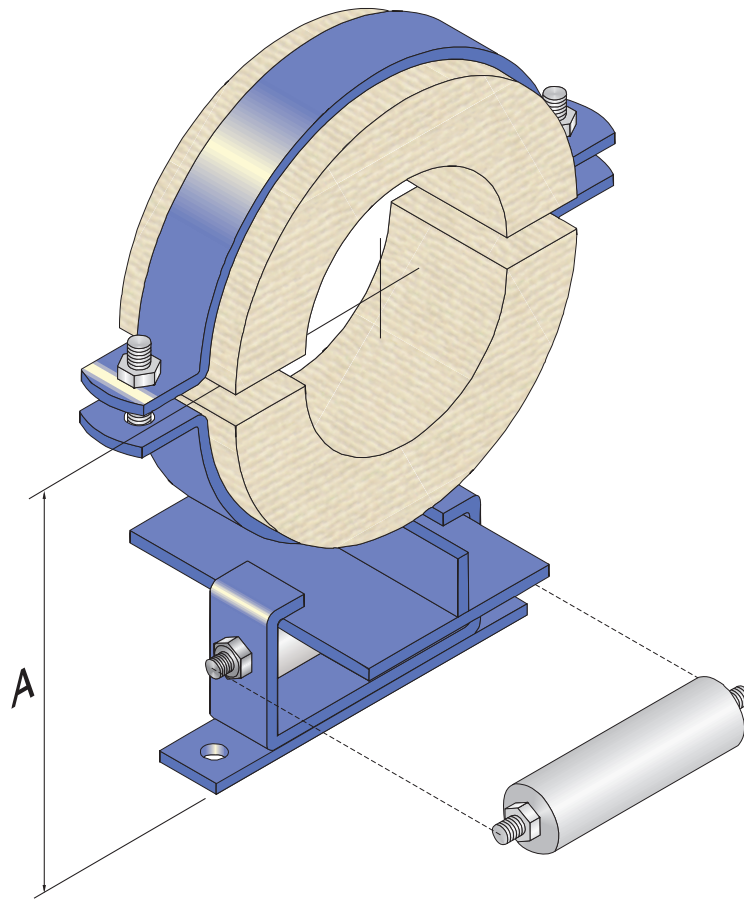

PART NO.	PIPE DIA.	INS.	FERRULE DIA.	A	PART NO.	PIPE DIA.	INS.	FERRULE DIA.	A
FM147-015A	15nb	25	21 x 73	115	FM147-050A	50nb	25	60 x 115	136
FM147-015B		38	21 x 102	129	FM147-050B		38	60 x 140	150
FM147-015C		50	21 x 127	144	FM147-050C		50	60 x 165	163
FM147-020A	20nb	25	27 x 76	116	FM147-065A	65nb	25	73 x 127	144
FM147-020B		38	27 x 102	129	FM147-065B		38	73 x 152	156
FM147-020C		50	27 x 127	144	FM147-065C		50	73 x 178	169
FM147-025A	25nb	25	34 x 83	120	FM147-080A	80nb	25	89 x 140	150
FM147-025B		38	34 x 115	136	FM147-080B		38	89 x 165	163
FM147-025C		50	34 x 140	150	FM147-080C		50	89 x 190	175
FM147-032A	32nb	25	43 x 89	123	FM147-100A	100nb	25	115 x 165	163
FM147-032B		38	43 x 115	136	FM147-100B		38	115 x 190	175
FM147-032C		50	43 x 140	150	FM147-100C		50	115 x 220	190
FM147-040A	40nb	25	48 x 102	129					
FM147-040B		38	48 x 127	144					
FM147-040C		50	48 x 152	156					

FINISH: GALVANISED

'A' DIMENSION IS A MINIMUM, CAN BE INCREASED TO SUIT INDIVIDUAL ON-SITE REQUIREMENTS

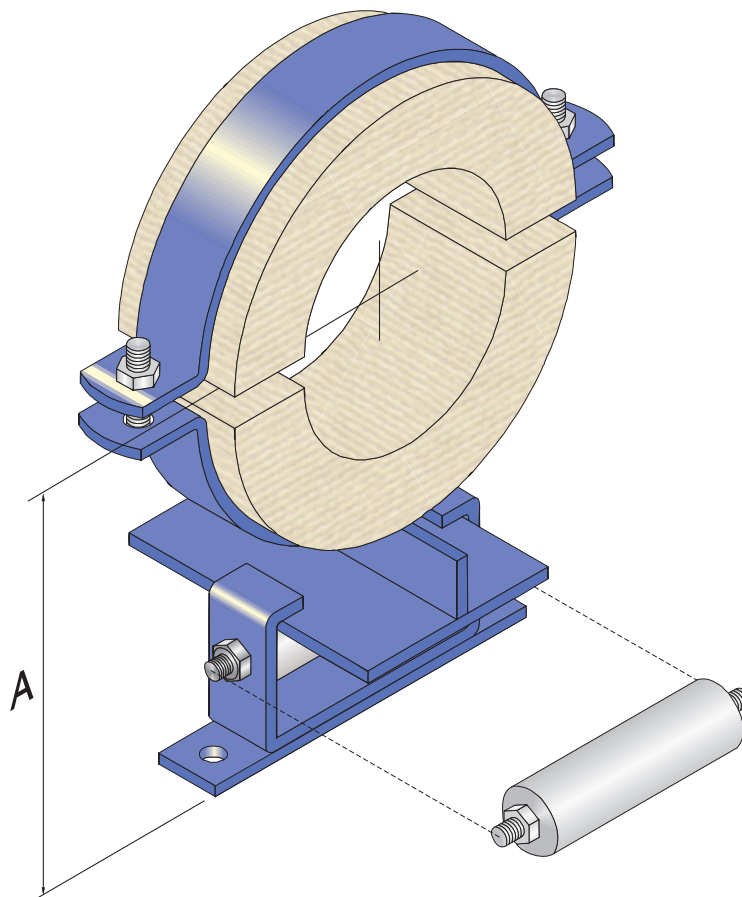

PART NO.	PIPE DIA.	INS.	FERRULE DIA.	A
FM147-015D	15cu	25	13 x 65	110
FM147-015E		38	13 x 89	123
FM147-015F		50	13 x 115	136
FM147-020D	20cu	25	19 x 70	114
FM147-020E		38	19 x 102	129
FM147-020F		50	19 x 127	144
FM147-025D	25cu	25	25 x 76	116
FM147-025E		38	25 x 102	129
FM147-025F		50	25 x 127	144
FM147-032D	32cu	25	32 x 83	120
FM147-032E		38	32 x 115	136
FM147-032F		50	32 x 140	150
FM147-040D	40cu	25	38 x 89	123
FM147-040E		38	38 x 115	136
FM147-040F		50	38 x 140	150

PART NO.	PIPE DIA.	INS.	FERRULE DIA.	A
FM147-050D	50cu	25	51 x 102	129
FM147-050E		38	51 x 127	144
FM147-050F		50	51 x 152	156
FM147-065D	65cu	25	65 x 115	136
FM147-065E		38	65 x 140	150
FM147-065F		50	65 x 165	163
FM147-080D	80cu	25	76 x 127	144
FM147-080E		38	76 x 152	156
FM147-080F		50	76 x 178	169
FM147-100D	100cu	25	102 x 152	156
FM147-100E		38	102 x 178	169
FM147-100F		50	102 x 203	181

FINISH: GALVANISED

‘A’ DIMENSION IS A MINIMUM, CAN BE INCREASED TO SUIT INDIVIDUAL ON-SITE REQUIREMENTS



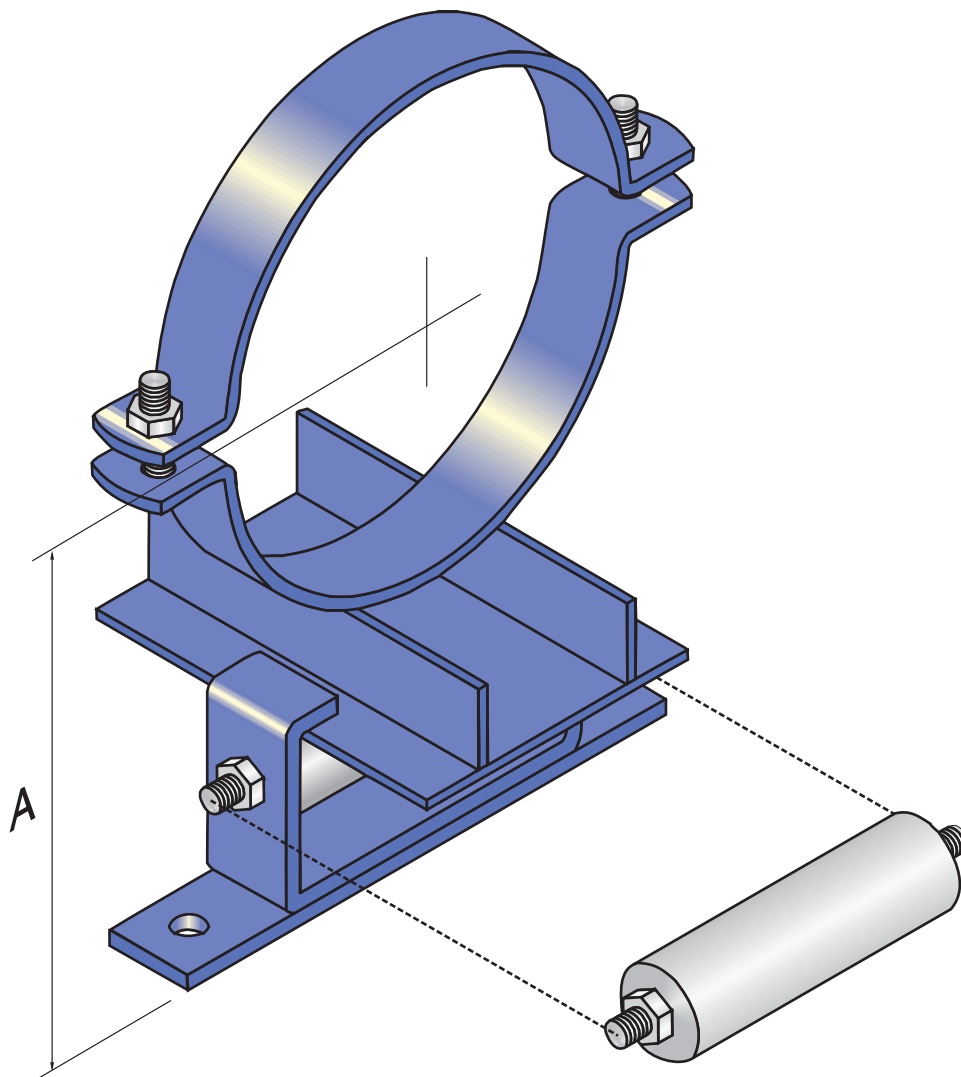

FM148 HEAVY DUTY ROLLER GUIDE FOR STEEL PIPE		
PART NO.	PIPESIZE	A
FM148-168	150nb	185
FM148-220	200nb	211
FM148-273	250nb	238
FM148-324	300nb	267
FM148-355	350nb	283
FM148-406	400nb	308
FM148-506	500nb	360
FM148-610	600nb	412

FINISH: GALVANISED

FM148 HEAVY DUTY ROLLER GUIDE FOR COPPER PIPE		
PART NO.	PIPESIZE	A
FM148-152	150cu	177
FM148-203	200cu	203
FM148-254	250cu	228
FM148-304	300cu	253

**FINISH: POLYESTER
POWDER COATED**

**'A' DIMENSION IS A MINIMUM, CAN BE INCREASED
TO SUIT INDIVIDUAL ON-SITE REQUIREMENTS**

FM149

HEAVY DUTY ROLLER GUIDE AND TIMBER FERRULE FOR STEEL PIPE

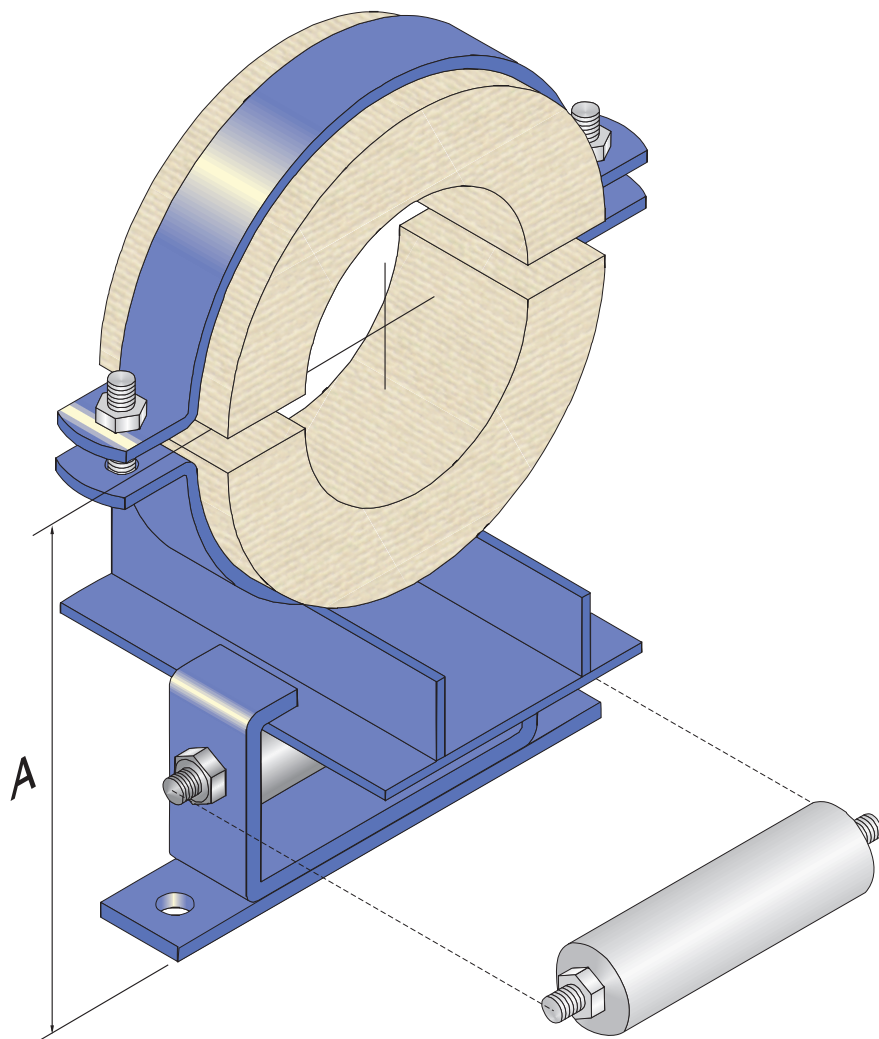

PART NO.	PIPE DIA.	INS.	FERRULE DIA.	A	PART NO.	PIPE DIA.	INS.	FERRULE DIA.	A
FM149-125A	125nb	25	140 x 190	195	FM149-300A	300nb	25	324 x 375	289
FM149-125B		38	140 x 220	210	FM149-300B		38	324 x 406	308
FM149-125C		50	140 x 240	220	FM149-300C		50	324 x 424	317
FM149-150A	150nb	25	168 x 220	210	FM149-350A	350nb	25	355 x 406	308
FM149-150B		38	168 x 240	220	FM149-350B		38	355 x 424	317
FM149-150C		50	168 x 268	235	FM149-350C		50	355 x 457	334
FM149-200A	200nb	25	220 x 275	238	FM149-400A	400nb	25	406 x 457	334
FM149-200B		38	220 x 300	251	FM149-400B		38	406 x 483	345
FM149-200C		50	220 x 324	263	FM149-400C		50	406 x 508	359
FM149-250A	250nb	25	273 x 324	263	FM149-450A	450nb	25	455 x 508	359
FM149-250B		38	273 x 356	279	FM149-450B		38	455 x 533	372
FM149-250C		50	273 x 375	289	FM149-450C		50	455 x 557	384

FINISH: GALVANISED

‘A’ DIMENSION IS A MINIMUM, CAN BE INCREASED TO SUIT INDIVIDUAL ON-SITE REQUIREMENTS



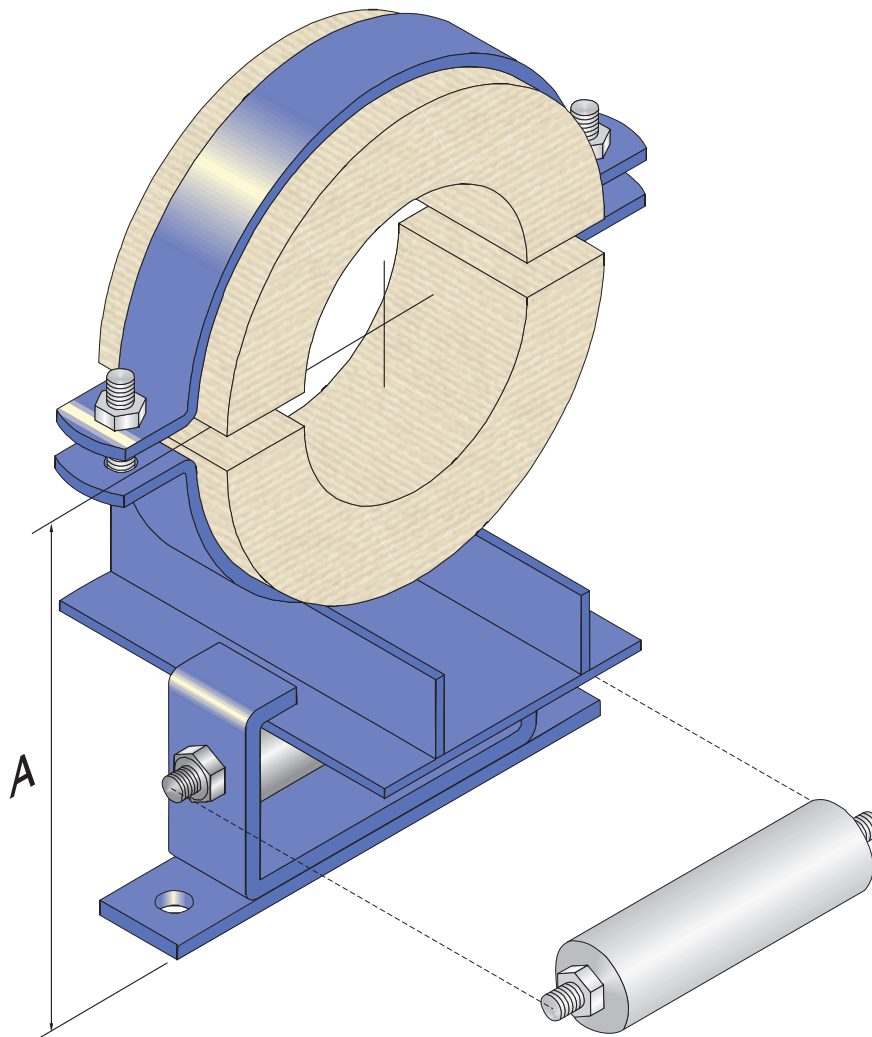

PART NO.	PIPE DIA.	INS.	FERRULE DIA.	A
FM149-125D	125cu	25	127 x 178	189
FM149-125E		38	127 x 203	202
FM149-125F		50	127 x 228	214
FM149-150D	150cu	25	152 x 203	202
FM149-150E		38	152 x 228	214
FM149-150F		50	152 x 252	226
FM149-200D	200cu	25	203 x 252	226
FM149-200E		38	203 x 275	238
FM149-200F		50	203 x 300	251
FM149-250D	250cu	25	254 x 300	251
FM149-250E		38	254 x 330	266
FM149-250F		50	254 x 355	279

FINISH: GALVANISED

'A' DIMENSION IS A MINIMUM, CAN BE INCREASED TO SUIT INDIVIDUAL ON-SITE REQUIREMENTS